



**PASCO Specialty & Mfg., Inc.**

11156 Wright Road  
Lynwood, CA 90262  
Phone (310) 537-7782  
Fax (800) 737-2726

7529 Perryman Court  
Curtis Bay, MD 21226  
Phone (410) 360-5010  
Fax (877) 377-6466

www.pascospecialty.com

**TECHNICAL SPECIFICATION SUBMITTAL**

Lead free water works brass couplings to install between municipal water meters and structures

Job Name \_\_\_\_\_ Date \_\_\_\_\_

Model Specified \_\_\_\_\_ Quantity \_\_\_\_\_

Customer/Wholesaler \_\_\_\_\_

Contractor \_\_\_\_\_

Architect/Engineer \_\_\_\_\_

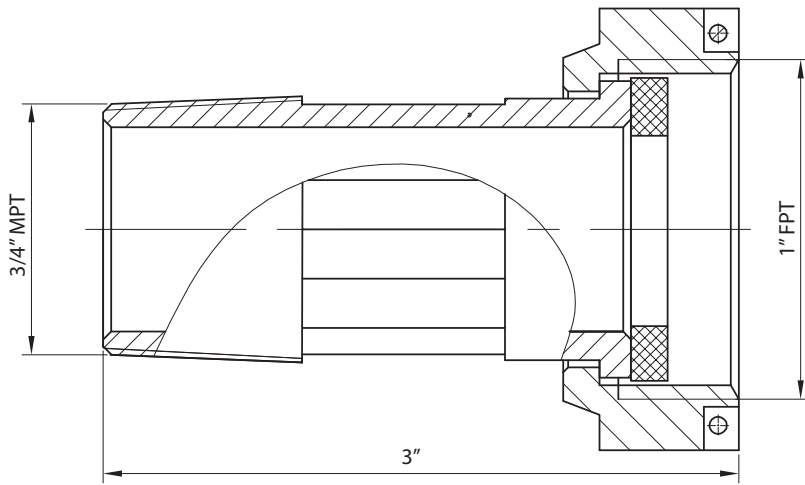

#7601

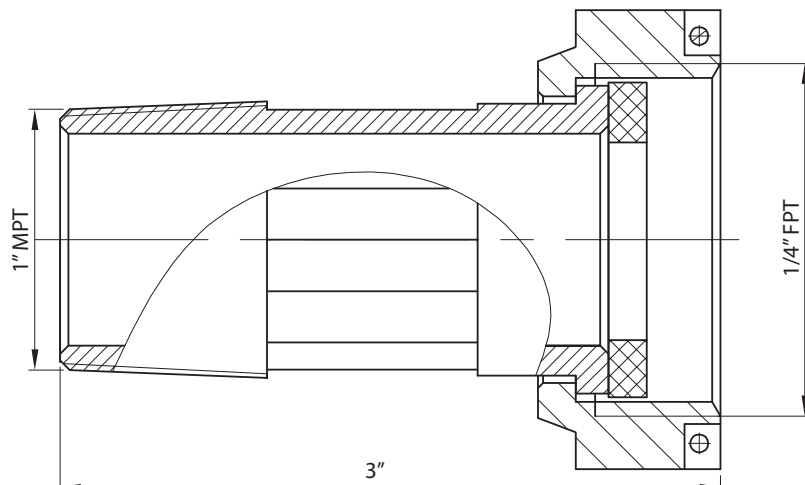

#7602

**Compliant**   
 AB 1953

**Sold individually w/ washers**

PART NUMBER	SIZE
7601	3/4" Straight
7602	1" Straight

**Washers Only**

PART NUMBER	SIZE
7608	3/4"
7609	1"